

CAHB-20

Linear Actuator



Read this manual before installing, operating or maintaining this actuator. Failure to follow safety precautions and instructions could cause actuator failure and result in serious injury, death or property damage.



Contents

1 General information	3	6 Installation and first operation	21
1.1 Information on this manual	3	6.1 Installation location	22
1.2 Explanation of symbols	3	6.2 Installation	22
1.3 Limitation of liability	4	6.3 Inspections prior to first operation	24
1.4 Warranty terms	5	6.4 Connect to power supply	24
1.5 Customer service	5		
2 Safety	6	7 Operation	25
2.1 Intended use	6	7.1 Safety	25
2.2 Responsibility of the owner and processor	6	7.2 Action before operation	26
2.3 Personnel requirements	7	7.3 Action during operation	27
2.3.1 Qualifications	7	7.3.1 Normal operation	27
2.4 Specific dangers	8	7.4 Disengagement in case of emergency	29
2.5 Safety equipment	9	7.5 Action after use	29
2.6 Changes and modifications on the actuator	11		
3 Technical data	12	8 Maintenance	30
3.1 Operating conditions	12	8.1 Spare parts	30
3.2 Product label	12	8.2 Maintenance plan	31
		8.3 Maintenance work	32
		8.3.1 Cleaning	32
		8.3.2 Inspections and readings	32
		8.3.3 Check of visual condition	33
		8.4 Measures after completed maintenance	33
4 Structure and function	13	9 Malfunctions	34
4.1 Overview	13	9.1 Malfunction table	36
4.2 Brief description	14	9.2 Start of operation after fixing malfunction	37
4.3 Special features	15		
4.4 Construction group description	15	10 Dismantling	38
4.5 Connections	16	10.1 Dismantling	39
4.6 Options	16	10.1.1 Dismantling of CAHB-20	39
4.6.1 Limit switch	16	10.2 Disposal	39
4.6.2 Potentiometer	17		
4.6.3 Thermal switch	17		
5 Transport, packaging and storage	18	11 Appendix	40
5.1 Safety information for the transport	18		
5.2 Transport inspection	18		
5.3 Return to the manufacturer	19		
5.4 Packaging	19		
5.5 Storage	20		

1 General information

1.1 Information on this manual

This manual provides important information on how to work with the actuator safely and efficiently.

The manual is part of the actuator, must always be kept in the actuator's direct proximity and should be available for the personnel at any time. All personnel working with the actuator must read and understand this manual before starting any work. Strict compliance with all specified safety notes and instructions is a basic requirement for safety at work.

Moreover, the accident prevention guidelines and general safety precautions applicable at the place of use of the actuator must also be complied with.

For better representation of circumstances, the illustrations used are not necessarily to scale and may vary from the actual design of the actuator.

1.2 Explanation of symbols and signal words

Safety Precautions

Safety precautions are identified by symbols and signal words. These signal words indicate the severity of the hazard.

Adhere to these safety precautions and act cautiously in order to avoid accidents, personal injuries and damage to property.



Note!

Emphasizes useful hints and recommendations as well as information for efficient and trouble-free operation.

CAUTION

Indicates a dangerous situation, which can lead to minor or moderate personal injury or property damage, if the precautionary measures are ignored.

WARNING

Indicates a dangerous situation, which can lead to severe personal injury or death, if the precautionary measures are ignored.

DANGER

Indicates a dangerous situation, which will lead to death or severe personal injury, if the precautionary measures are ignored.

1.3 Limitation of liability

All information and notes in this manual were compiled under due consideration of valid standards and regulations, the present status of technology and our years of knowledge and experience.

The manufacturer will not be liable for damage resulting from:

- disregarding this manual
- unintended use
- employment of untrained personnel
- unauthorized conversions
- technical modifications
- manipulation or removal of the screws on the actuator
- use of unapproved spare parts

In case the actuator is customised, the actual product delivered may be different from what is described in the manual. In this case, ask SKF for any additional instructions or safety precautions relevant to these actuators.

We reserve the right to make technical modifications to the actuator to improve usability.

1.4 Warranty terms

The applicable and effective warranty terms are those contained in the manufacturer's terms and conditions of sale.

1.5 Customer service

SKF Customer Service is always available to provide technical information and answer questions.

See the contact information for SKF Customer Service on the back cover.

2 Safety

This chapter provides an overview of important safety precautions and information necessary for safe and trouble-free installation, operation and maintenance.

Disregarding this Manual and safety precautions specified therein may result in considerable danger and possible serious injury or death.

2.1 Intended use

The actuator has been designed and built exclusively for its intended purpose as described in these instructions.

WARNING

Risk from misuse!

Any utilization of this actuator beyond its intended purpose may lead to potentially hazardous situations.

Therefore:

- Strictly adhere to all safety precautions and instructions in this manual.
- Do not allow this actuator to be subjected to weather conditions, strong UV rays, corrosive or explosive air media as well as other aggressive media.
- Do not modify, retool or change the structural design or individual components of the actuator.
- Never use the actuator outside of the technical application and operational limits.

Any injury, damage or loss caused by violation of these instructions will be the responsibility of the customer.

2.2 Responsibility of the owner and processor

The actuator is designed for personal use and is also used in commercial applications by owner or processors.

The processor is the contracting partner of the reseller or the manufacturer. The processor installs the actuator in a complete system (application).

The owner of the system is therefore subject to requirements of the Occupational Health and Safety Act.

In addition to the safety instructions in this Manual, the owner or processor must do the following concerning these safety and acci-

dent prevention guidelines and environmental precautions regulations applicable to the site of the system's installation:

- Inform themselves of applicable industrial safety precautions and determine additional hazards that arise due to the specific working conditions prevailing at the site where the actuator is installed using risk assessment. The risk assessment must be implemented in the form of work instructions for the actuator operation.
- Confirm that the work instructions created for the system including the actuator satisfy current legal requirements and must alter the instructions if they don't.
- Clearly regulate and specify the responsibilities for installation, operation, maintenance, and cleaning.
- Ensure that all employees who deal with the actuator have read and understood this Manual.
- Provide personnel with the required protective equipment.

In addition, owner must train personnel at regular intervals and inform personnel of the hazards.

In addition, owner or processors must ensure that the actuator is in an adequate working condition. They must do the following:

- Ensure that the maintenance intervals described in these instructions are complied with.
- Have all safety devices inspected regularly for function and completeness.

2.3 Personnel requirements

WARNING

Risk from misuse!

Improper installation, operation and maintenance can result in serious injury, death or property damage.

Use only qualified, instructed, or trained personnel (as described below) who have read, understand and follow these instructions.

2.3.1 Qualifications

The following qualifications are specified for different areas of activity listed in the Manual.

- **An instructed person (Operator)**
has been instructed by the customer in an orientation session on the assigned tasks and possible dangers in case of improper behaviour.
- **Qualified personnel**
based on their professional training, know-how and experience as well as knowledge of the applicable standards and regulations is able to perform assigned work activities and to detect and avoid possible dangers on their own.

- **A professional electrician**

based on his/her professional training, know-how and experience as well as knowledge of the applicable standards and regulations is able to perform work on electrical systems and to detect and avoid possible dangers on his/her own.

The professional electrician has been trained for the special location where he/she works and knows the relevant standards and regulations.

Only persons who are expected to perform their tasks reliably are permitted as personnel. Persons whose reaction capability is impaired, e.g. through drugs, alcohol or medication, are not permitted.

2.4 Specific dangers

The following section lists the residual risks that have been determined by the risk assessment.

- **Heed the safety instructions listed here, and the warnings in subsequent chapters of this Manual, to reduce health hazards and to avoid dangerous situations.**

 **DANGER**

Danger to life caused by electric current!

Touching conductive parts causes a direct danger to life. Damage to insulation or individual components can cause danger to life.

Therefore:

- In the event of damage to insulation, switch off the power supply immediately and have the parts repaired.
- Work on the electrical system must be carried out only by professional electricians.
- De-energize the machine for all work on the electrical system.
- Before maintenance, cleaning or repair work, switch off the power supply and perform lockout procedures so it cannot be turned on again.
- Do not bridge fuses or make them ineffective. When changing fuses, make sure you use the correct amperage.
- Keep moisture away from conductive parts. If you don't, this can cause short circuit.



Electric current

 **WARNING**

Danger of injury caused by moving components!

Rotating and/or linearly moving components can cause severe injury.

Therefore:

- Do not work on or place any of your body, hands, or arms near moving components.

Moving components

2.5 Safety equipment

 **WARNING**

Danger due to malfunctioning safety equipment!

For safe operation, be sure all safety equipment is in good working order.

Therefore:

- Always check functionality of safety equipment according to the maintenance plan.
- Never disengage safety equipment.
- Safety equipment may never be by-passed or modified.

Integration in an emergency-stop system required (for certain applications)

The actuator is only intended for installation into an application or system. It does not have its own operating control elements and does not have an independent emergency-stop-function.

Install the actuator so that it is part of an emergency shut-off system and can be stopped if necessary.

The emergency shut-off system has to be connected in such a way that a disruption of the power supply or the reactivation of the power supply after a power disruption cannot cause a hazardous situation for persons and objects.

The emergency shut-off systems must always be freely accessible.



Note!

The processor decides which applications require the installation of an emergency shut-off system.

The following safety features may have been installed:

In its standard version, the actuator does not feature a thermal switch protection and can be damaged through overheating.

A thermal limit switch is an option and can be integrated in the motor housing.

Thermal switch (optional)

 **CAUTION**

To prevent damage from overheating, do not try to operate actuator until its temperature has fallen below the threshold for the switch to operate.

A lead screw nut converts the rotation of the gear unit into linear motion. If an overload occurs when the actuator is operating, a ball detent clutch will operate, thus stopping linear motion.

Overload protection

 **CAUTION**

Continued operation of the clutch can result in overheating and damage to the linear actuator. If clutch activates, switch off power immediately.

 **CAUTION**

Clutch activation can cause the limit switch to stop functioning. If this happens, have an SKF engineer adjust it so that it again operates properly.

2.6 Changes and modifications on the actuator

To avoid hazardous situations and to ensure optimal performance, do not make any changes or modifications to the actuator unless they have been specifically authorized by SKF.

3 Technical data



Note!

The technical data (dimensions, weight, output, connection values etc.) can be found in the enclosed drawings and data sheets (→ **Appendix**).

3.1 Operating conditions

Environment

Information	Value	Unit
Temperature range	-40 to +85	°C
Relative atmospheric humidity, maximum (no build up of condensation)	up to 85	%

Duration (intermittent)

Information	Value	Unit
Maximum operating time without a break	1	Cycles
Break until next operation	3	Times of operating time

3.2 Product label

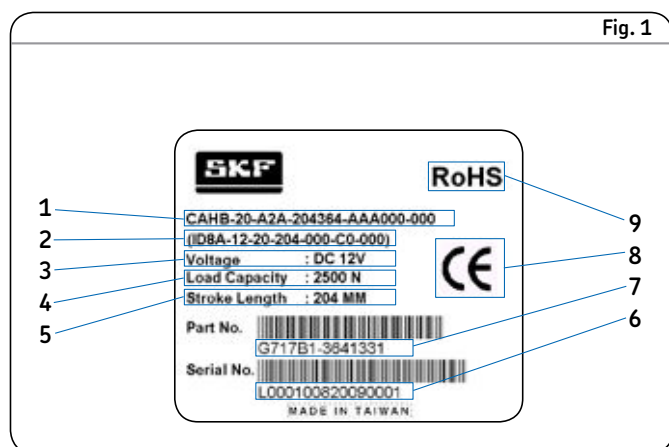

Fig. 1

The product label provides the following information

- 1 Identification of actuator
- 2 Identification of actuator (Old type key)
- 3 Power voltage
- 4 Load capacity
- 5 Stroke length
- 6 Serial number
- 7 Part number
- 8 CE mark
- 9 ROHS mark

4 Structure and function

4.1 Overview

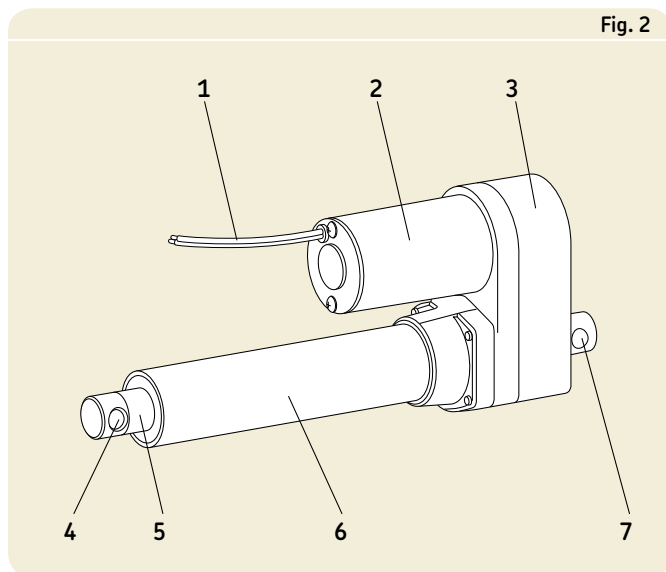
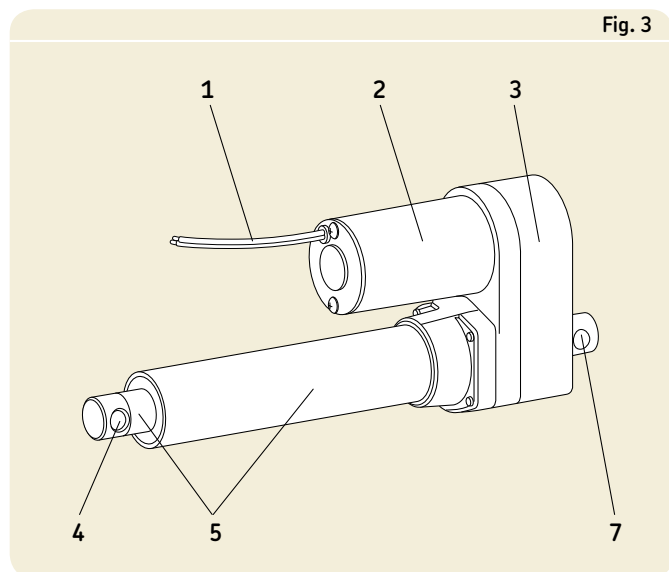

Fig. 2

CAHB-20

- 1 Cable
- 2 Motor part
- 3 Gearbox
- 4 Front hinge head
- 5 Push tube
- 6 Guide tube
- 7 Rear hinge head

4.2 Brief description



Overview

This actuator is to be used exclusively for installation into a dynamic centric-compression or tensile-loaded lift.

The linear actuator consists of a motor part (3) and a linear unit (5), connected with each other by a bayonet joint.

The actuator consists of a direct current motor with spur gear which sets in motion a trapezoidal sliding spindle system with shaft joint. Via the lead screw mount, the sliding spindle transforms the rotation of the gear into a linear motion of the actuator (1).

The front hinge head (4) and the rear hinge head (7) transmit the actuator power to both sides of the application.

4.3 Special features

Mechanical overload protection

The actuator contains a mechanical overload protection unit (clutch). This overload protection unit will activate if the linear unit of the actuator overloads. This activation will protect the motor and gear unit from being damaged.

CAUTION

Continued operation of the clutch can result in overheating and damage to the linear actuator. If clutch activates, switch off power immediately.

CAUTION

Clutch activation can cause the limit switch to stop functioning. If this happens, have an SKF engineer adjust it so that it again operates properly.

CAUTION

Incorrect activation of clutch could cause actuator damage. Limit stroke of linear actuator using internal/external limit switch or other electrical component.

4.4 Construction group description

Motor

The motor is a 12 or 24 V DC. The motor's shaft powers a spur gear. The lift speed depends on the load. The motor unit is surrounded by metal housing. The metal housing cannot be opened.

Gear unit

The spur gear is directly powered by the motor shaft which moves a trapezoidal sliding spindle.

Linear unit

The actuator extends and retracts the push tube. The linear unit is surrounded and protected by the guiding tube. The push tube of the actuator is connected to the spindle with a lead screw nut.

The linear unit is connected to the motor with several screws. These screws should not be loosened or removed.

4.5 Connections

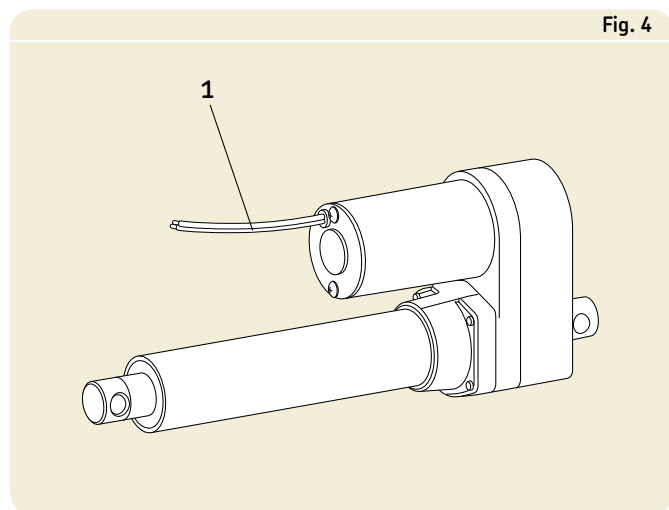

Fig. 4

CAHB-20 connections

- 1 Wires to connect actuator to power supply or to an external control.

4.6 Options

If not specified otherwise, the options listed below are available for the entire series of CAHB-20 linear actuators.

4.6.1 Limit switch

The limit switch makes it possible to control the stroke of the linear unit by internal setting.

WARNING

If mechanical overload protection unit activates, the limit switch can malfunction.

Contact the SKF to adjust the setting of limit switch.

4.6.2 Potentiometer

The potentiometer provides a signal indicating the position of the linear actuator.

There are two types of settings for the potentiometer wire.

- Linear actuator with potentiometer and limit switch units: colours of wire are white, red and black (→ Fig. 11).
- Linear actuator with potentiometer unit: colours of wire are white, green and brown (→ Fig. 11).

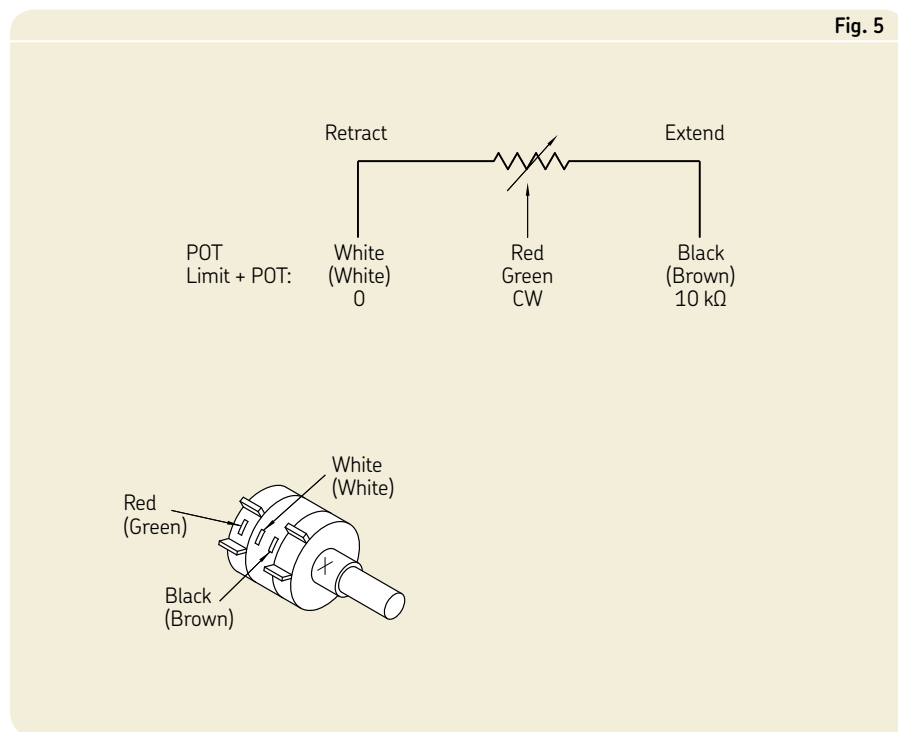

Potentiometer

4.6.3 Thermal switch

The thermal switch in the motor controls thermal overload by switching off the motor in an emergency.

⚠ CAUTION

To prevent damage from overheating, do not try to operate actuator until its temperature has fallen below the threshold for the switch to operate.

5 Transport, packaging and storage

5.1 Safety information for the transport

CAUTION

Significant actuator damage can occur if not properly transported, unpacked and stored.

Therefore:

- Proceed carefully during the unloading of the packaged items, during the delivery as well as during the transport to its final destination and comply with the symbols and information shown on the packaging.
- Only remove the actuator from its packaging right before installation.
- Note storage requirements for return transport to the manufacturer (→ Chapter *Storage*).

Improper transport

5.2 Transport inspection

The CAHB-20 linear actuator is delivered as one packaged unit in a box or on pallets.

Check the delivery for completeness and damage due to transport immediately upon receipt. Send back actuator to manufacturer if it has cracks in the casing caused during transportation.

Check completeness of delivery:

- A complete actuator unit.
If damage to the exterior of the actuator has occurred during transport, do the following:
- Do not accept delivery or do so only with reservations.
- Record scope of damage on the transport documents or on the bill of delivery of the shipping company.
- Initiate complaint.

Note!

Report any damage as soon as it has been identified. Damage claims can only be asserted within the transporter's applicable complaint period.

5.3 Return to the manufacturer

Proceed as follows for the return transport:

- 1 Dismantle the actuator if necessary (→ Chapter *Dismantling*).
- 2 Pack the actuator in its original packaging. Follow storage conditions (→ Chapter *Storage*).
- 3 Send to manufacturer. The address is listed on **page 2**.

5.4 Packaging

For packaging

The individual packaged pieces have been packaged appropriately according to the expected transport conditions.

The packaging is supposed to protect the individual components from damage caused by the transport, corrosion and other damage until they are ready for installation. Therefore, do not destroy the packaging and only remove the actuator shortly prior to the installation. Keep packaging for possible return shipment to the manufacturer (→ **Chapter 5.3**).

If the packaging is to be disposed off, please adhere to the following:



Note!

Environmental damage due to incorrect disposal!

Packaging material consists of valuable raw materials, which, in many cases, can be recycled.

Therefore:

- Dispose of packaging material in an environmentally correct way.
- Comply with locally applicable disposal regulations.

Handling of packaging materials

5.5 Storage

Pack the actuator in its original packaging for storage.

- Do not store outside.
- Dry and dust-free storage.
- Keep away from any aggressive media.
- Protect from UV radiation.
- Avoid mechanical vibrations.
- Storage temperature: -20 to 40 °C.
- Relative atmospheric humidity: max. 95% (no build up of condensation).
- For storage for longer than three months, check the general condition of all parts of the packaging on a regular basis. If necessary, refresh or renew the conservation.



Note!

It is possible that there are notices on the packaging concerning additional storage requirements. If so, follow all requirements.

6 Installation and first operation

Authorized personnel

- The installation and first start of operation may only be conducted by qualified personnel.
- Work on the electric system may only be performed by trained electricians.

WARNING

Electric shock and moving parts hazards

Serious injury or death can be caused by touching live electrical components and by unexpected movement of the actuator.

Be sure the system's power supply is off and actuator is locked out before installing.



Electrical equipment

WARNING

Danger if restarted without authorization!

When correcting faults, there is danger of the energy supply being switched on without authorization. This poses a life-threatening hazard for persons in the danger zone.

Therefore:

- Prior to starting work, switch off the system and safeguard it from being switched on again.



Safeguarding against restart

WARNING

Risk of injury and material damage due to incorrect installation of the optional devices!

Therefore:

- Optional devices, in particular components that are part of a retrofitting, may only be installed in accordance with the respective instructions (circuit diagram).
- The electromagnetic compatibility must be tested for the routing and appropriate measures must be carried out if necessary.



Optional devices

6.1 Installation location

- Adhere to the technical data in accordance with operating conditions (→ **chapter 11 Appendix**).
- Install in a location where the actuator is not exposed to strong UV radiation or corrosive or explosive air media.

6.2 Installation

The CAHB-20 linear actuator is attached to two elements via the hinge heads.

- 1 Connect the hinge heads (**1** and **2**, **Fig. 6**) to the appropriate elements of the application with the fastening bolts.

Fig. 6

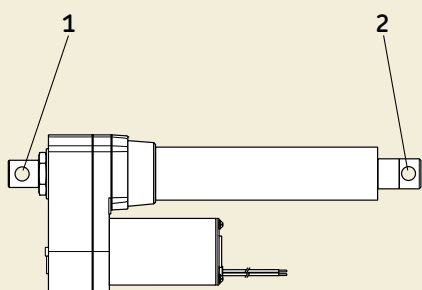

Note!

Information concerning the dimensions of the drill holes for fastening bolts can be found in the respective data sheets. (→ *Appendix*).

WARNING

Risk of injury and material damage due to insufficient fastening!

Only use fastening bolts and secure them adequately. Do not use screws to install. Never loosen or otherwise manipulate screws on actuator or options.

- 2 Ensure that the applied force on the fastening bolts is always centrally directed on the actuator (→ Fig. 7).

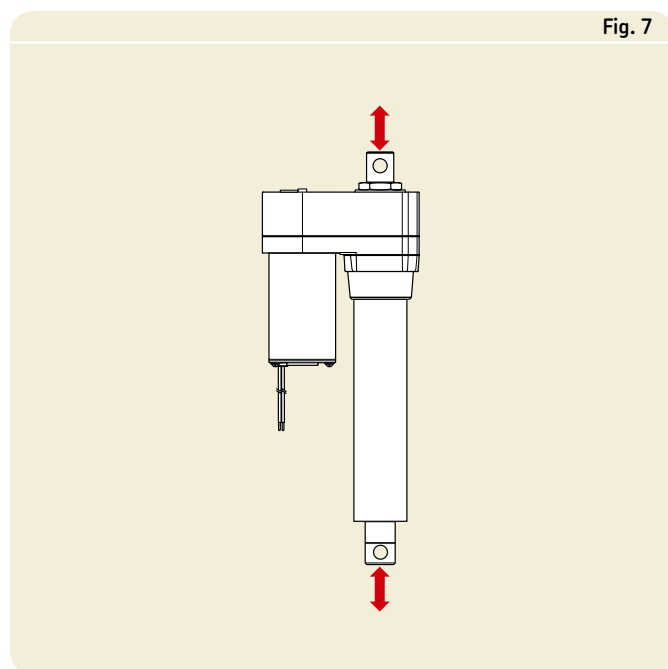

⚠ WARNING

Risk of injury and material damage due to incorrect installation!

During installation, do not subject the actuator to side-impact or to turning forces.

- 3 During installation, be sure that the linear actuator is not impacted in its movement over the entire stroke area.
- 4 During installation, be sure that the motor cable is not squeezed, clamped or pulled.
- 5 Connect linear actuator to power supply (→ **Subchapter Connect to Power Supply**).
- 6 Ensure that none of the supply or control cables can be pinched by the kinematics of the application or by the linear actuator during the extension or retraction

6.3 Inspections prior to first operation

Prior to the first operation, a professional electrician must perform and document the following tests and readings:

- Check visual condition
- Function check of operating features and safety features
- Reading of protective conductor resistance
- Reading of leakage currents
- Reading of insulation resistance



Note!

Additional information concerning inspections and readings (→ Chapter *Maintenance*).

6.4 Connect to power supply

DANGER

Electrical shock hazard

Incorrect installation can result in serious injuries, death or damage.

Only professional electricians should work on electrical systems.



Electrical equipment

- 1 Connect cable to electric grid.
- 2 Actuator performs the extending and retracting as defined in **Table 1**.

Table 1

	Cable (Red)	Cable (Black)	Actuator (Standard)	Actuator (with limit switch)
I	-	+	Extending	Retracting
II	+	-	Retracting	Extending

7 Operation

7.1 Safety

DANGER

Risk of crushing!

Actuator may cause serious injuries while moving.
Therefore:

- Ensure that there are no persons in the stroke area of the actuator while in operation.
- Take note of maximum permissible operating data for the actuator. (→ Data sheets in **Chapter 11 Appendix**).
- Never tamper with the elements that are connected to the actuator while the actuator is in operation.

CAUTION

Risk of injury through contact with the hinge head!

Therefore:

- Do not let objects or body parts come in contact with the hinge head of the actuator.

CAUTION

Material damage due to static and dynamic overload of the actuator!

Therefore:

- Adhere to maximum permissible operating data for the actuator (→ Data sheets in **Chapter 11 Appendix**).
- Never exceed nominal load.
- Never tamper with the elements that are connected to the actuator while the actuator is in operation.

CAUTION

Actuator may be damaged if liquids penetrate the actuator during extension and retraction. Keep liquids away.

 **CAUTION**

Material damage through overheating!

Therefore:

- Only use control integrated thermal switch.
- Never exceed nominal load. (→ technical data in **Chapter 11 Appendix**).
- Always adhere to idle times and operating times. (→ technical data in **Chapter 11 Appendix**).

7.2 Action before operation

Ensure that there are no persons or objects in the stroke area of the actuator.

7.3 Action during operation

7.3.1 Normal operation

During normal operation, the linear actuator lifts and lowers the elements that are connected with the CAHB-20 linear actuator via the hinge head.

The linear actuator can directly connect to electrical grid or be controlled by an operating element.

The linear actuator extends or retracts as long as the power is being supplied or until the linear actuator is completely extended or retracted.

The clutch will activate if the linear actuator is completely extended or retracted (except the linear actuator with an integrated optional limit switch). Prevent the linear actuator from completely extending or retracting by cutting off power before the end of the stroke or setting up the external limit switch.

The external limit switch has to cut off the power supply to the linear actuator immediately when the limit switch is activated and before the actuator is completely extended or retracted.

Any component that can perform the same function described above can be used.

CAUTION

Material damage through overheating!

Therefore:

- Only use control integrated thermal switch.
- Never exceed nominal load.
- Always adhere to idle times and operating times (→ technical data in **Chapter 11 Appendix**).

 **CAUTION**

Material damage due to incorrect set up of the limit switch!

Therefore:

- Select limit switch or other electrical component that is adequate for the rating voltage and current of linear actuator (→ Chapter *Technical data*).
- Consider the inertia of the movement of the linear actuator while setting up the position of the limit switch.
- Prior to starting work, run a function test to confirm that the external limit switch is operating properly.

 **DANGER**

Electrical shock hazard

Incorrect installation can result in serious injuries, death or damage.

Only professional electricians should work on electrical systems.



Electrical equipment

7.4 Disengagement in case of emergency

In hazardous situations, all movements of the actuator must be stopped as quickly as possible and the power supply must be turned off.

Proceed as follows in hazardous situations:

- 1 Immediately engage emergency shut-off, if present, or cut off power for actuator.
- 2 Evacuate people from the hazard zone, initiate first aid measures.
- 3 Notify responsible person on-site.
- 4 If rescue vehicles have been requested, keep access paths open for rescue vehicles.
- 5 Based on severity of emergency, notify the authorities if necessary.
- 6 Order specialized staff to repair malfunction.

WARNING

Do not restart until all persons are outside the hazard zone.
Check the actuator and application that uses the actuator prior to restarting the operation and ensure that all safety equipment is installed and fully functional

7.5 Action after use

Separate the actuator from the power supply.

8 Maintenance

Personnel

- The maintenance work described herein can be performed by the operator unless otherwise indicated.
- Some maintenance tasks should only be executed by especially trained, qualified personnel, or exclusively by the manufacturer; specific reference will be made in each case in the description of the respective maintenance task.
- Only professional electricians should perform work on the electrical equipment.

DANGER

Electrical shock hazard

Incorrect installation can result in serious injuries, death or damage.

Only professional electricians should work on electrical systems.



Electrical equipment

DANGER

Danger if restarted without authorization!

When correcting faults, there is danger of the energy supply being switched on without authorization. This poses a life-threatening hazard for persons in the danger zone.

Therefore:

- Prior to starting work, switch off the system and safeguard it from being switched on again.



Safeguarding against restart

8.1 Spare parts

The CAHB-20 linear actuator is not designed for repair work by the customer. All warranty and service claims become void without notice if any screws on the linear actuator have been manipulated.

 **WARNING**

Safety hazard caused by wrong spare parts!

Wrong or faulty spare parts can adversely affect safety and cause damage, malfunctions or total failure.

Therefore:

- Use only genuine spare parts from the manufacturer.
- Spare parts in/on the actuator may only be replaced by SKF.

The actuator must be dismantled and sent to the manufacturer. The address is listed on the **cover back**.

8.2 Maintenance plan

Maintenance tasks that are required for optimal and trouble-free operation are described in the sections below.

If increased wear is detected during regular inspections, shorten the required maintenance intervals according to the actual indications of wear.

Linear actuator CAHB-20 maintenance plan

Interval	Maintenance work	To be carried out by
Daily	Check actuator for visible damage (→ see below <i>Check of visual condition</i>)	Operator
	Clean off dust and dirt if necessary (→ see below <i>Cleaning</i>)	Operator
Monthly	Function check of operating features and safety features (→ see below <i>Inspections and readings</i>)	Qualified personnel
	Check tight fit of the actuator to the hinge head. Tighten if necessary	Qualified personnel
Annually	Check connection for tight fit	Professional electrician
As suggested by processor	Conduct visual inspection of the condition of the permanent safeguard and the routing of the supply and control cable within the application. Cable routing elements may not be loose or broken.	Qualified personnel



Note!

If the linear actuator is used outside of the environmental conditions specified earlier in this manual, check such components once a month for any changes such as oxidation or sedimentation.

8.3 Maintenance work

8.3.1 Cleaning

To be performed by operator

CAUTION

Damage due to incorrect cleaning!

Therefore:

- Do not use any aggressive cleaning agents. Water used for cleaning including the chemical additives must be pH-neutral.
- Liquids must not touch the actuator during the retraction or extension.
- Only use additional cleaning materials listed by the manufacturer.
- No steam jets or pressure washers may be used for cleaning.
- Other cleaning agents or cleaning devices may only be utilized with the manufacturer's approval.

Clean line actuator:

- 1 Separate the actuator from the energy supply.
- 2 Clean dirty parts with a damp cloth.

8.3.2 Inspections and readings

To be performed by professional electrician

- The inspections and readings must be performed as required by the applicable standards and regulations. The list of the applicable standards can be found in the appendix.
- The inspections must be documented (→ "Service Log").

Service log

Complete the following entries in the service log:

- Name of the executing body (company, department).
- Names of the staff on duty.
- Identification of the actuator/system (type, serial number, inventory number) and the respective accessories.
- Completed inspections and readings.
- Scope and results of the inspections.
- Measuring method, measuring device, measuring results for readings.
- Overall assessment.
- Date and signature of the assessing person; personal coding is a viable alternative for IT applications.

8.3.3 Check of visual condition

To be performed by qualified personnel

- 1 Separate the actuator from the energy supply.
- 2 Check the following structural components for visible external damage:

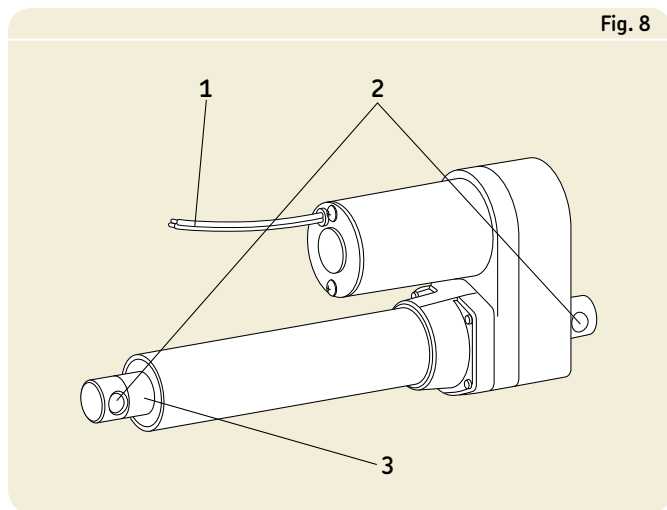

Fig. 8

- 1 Check connecting cables for cracks, cuts and pinched sections
- 2 Check hinge hole for cracks, deformation and broken pieces
- 3 Check stainless steel tube for scratches and indentations

- 3 Notify processor or SKF in case of damage
- 4 If there is no damage and the processors/manufacturer has not communicated any concerns, reconnect the actuator to the power supply.

8.4 Measures after completed maintenance

Upon completion of the maintenance work, the following steps have to be performed prior to restarting the actuator.

- 1 Check all previously loosened screw connections for a tight fit.
- 2 Ensure that all tools, material and other equipment used during maintenance have been removed from the work area.
- 3 Clean work area and remove potential spills such as liquids, processing material or similar.
- 4 Ensure that all safety measures of the system work properly without a problem.
- 5 Check to be sure that all actuator and system functions are operating correctly.
- 6 Document the the maintenance in the service log.

9 Malfunctions

The following chapter describes potential causes for malfunctions and the work that is necessary to restore operation.

In the event of frequent malfunctions, shorten the maintenance intervals.

Contact the manufacturer concerning malfunctions which are not solved by the following suggestions.

Personnel

- Unless indicated otherwise, the work described herein to solve malfunctions may be performed by the operator.
- Some work may only be carried out by qualified personnel, which is specifically indicated in the description of the individual malfunction.
- Work on the electric system may only be performed by professional electricians.

DANGER

Electric shock and moving parts hazards

Serious injury or death can be caused by touching live electrical components and by unexpected movement of the actuator.

Be sure power supply is off and actuator is locked out before installing.



Electrical equipment

DANGER

Danger if restarted without authorization!

When correcting faults, there is danger of the energy supply being switched on without authorization. This poses a life-threatening hazard for persons in the danger zone.

Therefore:

- Prior to starting work, switch off the system and safeguard it from being switched on again.



Safeguarding against restart

 **DANGER**

Risk of injury and material damage due to incorrect repair of malfunction

Therefore:

- Never loosen the screws on the linear actuator or try to open the linear actuator.
- In the event of a malfunction that cannot be fixed by adhering to the subsequent notices, dismantle the actuator and send it to the manufacturer for repair. (→ Chapter *Transport, packaging and storage*).



Optional devices

Behavior during malfunctions

In principle:

- 1 In the event of a malfunction that may present an immediate danger to persons or assets, turn off the actuator or control unit immediately and safeguard against a restart.
- 2 Determine cause of malfunction.
- 3 Depending on the type of a malfunction, have it repaired by qualified personnel.
- 4 Inform responsible party on-site concerning malfunction.



Note!

The following malfunction table provides information as to who is authorized to perform the repair.

9.1 Malfunction table

Malfunction	Possible cause	To repair malfunction	To be repaired by
Linear actuator doesn't move	No supply voltage	Check power supply	Professional electrician
	Lack of plug contact or plug has not been inserted properly	Plug contacts: Device control unit, control of voltage network. Check control operating element	Operator
	Defective network cable or power plug	Supply cable and plug of the lines: Check actuator control unit, control of voltage network control operating element for damage, if necessary replace defective elements	Professional electrician
	Obstacle in the stroke area of the linear actuator	Remove all obstacles in the stroke area	Operator
	Incorrect load	Measure static and dynamic load and compare with information concerning the product label. If the load capacity is exceeded, check the nominal load and install stronger actuator if necessary.	Qualified personnel
	Lifespan of the actuator is exceeded	If the actuator has performed more than 20,000 double strokes (100 mm stroke, 25% duty cycles, nominal load, 25 °C), the actuator needs to be replaced.	Qualified personnel
Linear actuator cannot be set in motion by any of the above listed measures.	Exchange actuator	Qualified personnel	
Linear actuator cannot be lifted	Obstacle in the stroke area of the linear actuator	Remove all obstacles in the stroke area	Operator
	Incorrect load	Remove all loads that are on the elements.	Operator
	Defective screw nut	Exchange actuator	Qualified personnel
Significantly reduced speed	Obstacle in the stroke area of the linear actuator	Remove all obstacles in the stroke area	Operator
	Incorrect load	Remove all loads that are on the elements.	Operator
	Defective motor, gear or screw nut	Exchange actuator	Qualified personnel
Significant increase in noise	Obstacle in the stroke area of the linear actuator	Remove all obstacles in the stroke area	Operator
	Incorrect load	Remove all loads that are on the elements.	Operator
	Defective motor, gear or screw nut	Exchange actuator	Qualified personnel

9.2 Start of operation after fixing malfunction

After the malfunction has been fixed, perform the steps from the chapter Installation prior to restart.

10 Dismantling

Personnel

- The dismantling may only be carried out by specifically qualified personnel.
- Work on the electric system may only be performed by professional electricians.

DANGER

Electric shock and moving parts hazards

Serious injury or death can be caused by touching live electrical components and by unexpected movement of the actuator.

Be sure power supply is off and actuator is locked out before installing.



Electrical equipment

WARNING

Risk of injury due to incorrect dismantling!

Stored residual power, sharp-edged components, pins and corners on the individual components or at the required tools can cause serious injuries.

Therefore:

- Ensure there is ample space for dismantling prior to starting with the work.
- Use caution when working with open, sharp-edged structural components.
- Ensure order and cleanliness at the dismantling site! Loosely stacked structural components or structural components and tools on the floor may present a source for accidents.
- Dismantle structural components professionally pursuant to applicable local regulations.
- Secure structural components in a way so they would not be able to fall or tip over.
- Contact the manufacturer if you have any questions or concerns.



Safeguarding against restart

10.1 Dismantling

10.1.1 Dismantling of CAHB-20

- 1 Separate actuator from energy supply (→ Chapter *Operation* → *Disengagement in case of emergency*).
- 2 Secure elements of the application in such a fashion, that no loads can impact the hinge heads.
- 3 Loosen and remove fastening bolts from the mounting strap of the hinge heads.
- 4 Separate linear actuator from application elements.
- 5 Clean actuator.
- 6 Carefully package for shipment to the manufacturer. (→ Chapter *Transport and packaging*).

10.2 Disposal

To the extent that no take-back or disposal agreement has been put in place, disassembled components should be recycled:

- Dispose of metals and plastic components at an appropriate recycling center.
- Sort remaining components based on the respective material and dispose of according to applicable local occupational health and environmental regulations.

CAUTION

Damage can be caused to the environment due to incorrect disposal!

Electronic waste, electronic components, lubricants and other additives are subject to special waste treatment regulations and may only be disposed of by approved specialized companies!

The local municipal authorities or specialized waste management companies can provide information concerning environmentally appropriate disposal.

11 Appendix

Technical data sheets

The following 4 pages are a reprint from
PUB MT/P2 10694 EN · April 2010

Linear actuator

CAHB-20 series

Features

- ACME screw drive
- Stainless steel extension tube
- Steel protection tube
- Enhanced corrosion resistance
- Mechanical overload protection (clutch)
- Lubricated for service life
- Robust, designed for tough environment
- Self-locking
- Certified (CE: EN 55011)



Connecting diagram

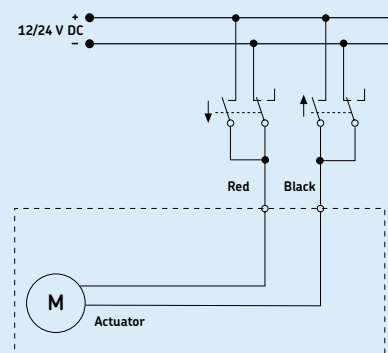

Dimensional drawing

Basic configuration (dashed line for optional limit switch)

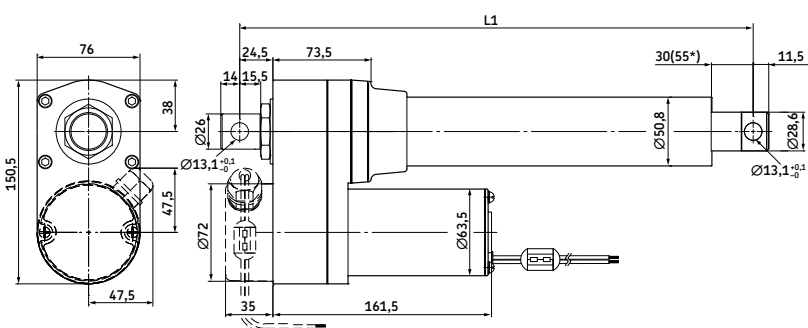

Different rear attachment

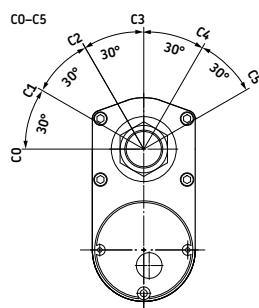

Without limit switch:
 RED (+) & BLACK (-) = retraction
 RED (-) & BLACK (+) = extension
 With limit switch:
 RED (+) & BLACK (-) = extension
 RED (-) & BLACK (+) = retraction

Legend:
 L1 = retracted length
 *55 = dimension with limit switch

	With limit switch ¹⁾						Without limit switch ²⁾					
Stroke (mm)	102	153	204	305	457	610	102	153	204	305	457	610
L1 Retracted length	338	389	440	592	744	897	262	313	364	465	668	821

¹⁾ Tolerance: S and L1 = ± 5,0 mm (If S ≥ 305 mm, S = ± 7,5 mm)
²⁾ Tolerance: S = ± 2,5 mm and L1 = ± 3,8 mm

Technical data

	Unit	CAHB-20... 1	CAHB-20... 2
Rated push load	N	1 500	2 500
Rated pull load	N	1 500	2 500
Speed (full load to no load)	mm/s	27 to 33	13 to 17
Stroke	mm	102 to 610	102 to 610
Retracted length	mm	-*	-*
Voltage	V DC	12 or 24	12 or 24
Current consumption	12 V DC 24 V DC	A A	A A
Duty cycle	%	25	25
Ambient temperature	°C	-40 to +85	-40 to +85
Type of protection	IP	66	66
Weight (at 305 mm stroke)	kg	5,5	5,5
Color	-	Black	Black

* see above table

Performance diagrams

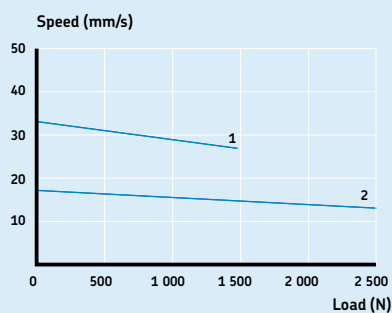

Speed-load diagram

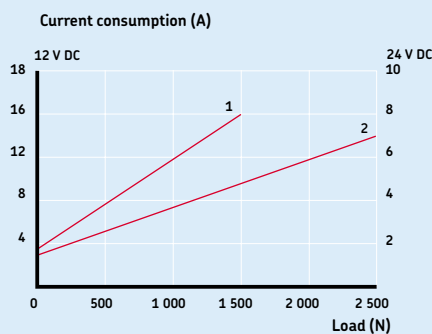

Current-load diagram

Dimensional drawing

Optional potentiometer

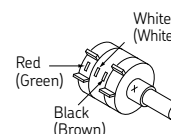
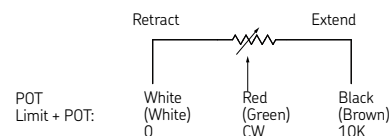
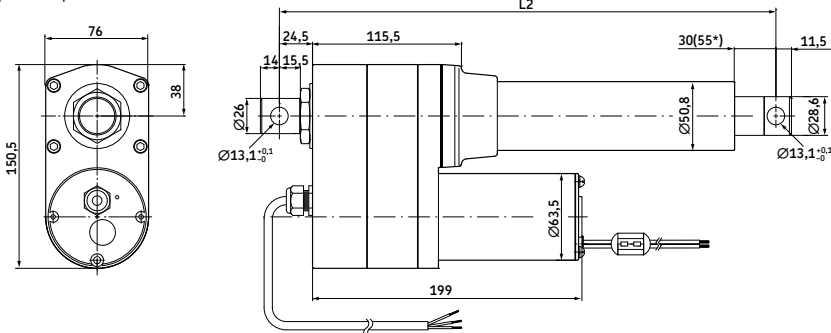

Without limit switch:
 RED (+) & BLACK (-) = retraction
 RED (-) & BLACK (+) = extension
 With limit switch:
 RED (+) & BLACK (-) = extension
 RED (-) & BLACK (+) = retraction

Legend:
 L2 = retracted length
 *55 = dimension with limit switch

Stroke (mm)	With limit switch ¹⁾						Without limit switch ²⁾					
	102	153	204	305	457	610	102	153	204	305	457	610
L2 Retracted length	376	427	478	630	782	935	300	351	402	503	706	859

¹⁾ Tolerance: S and L2 = ± 5,0 mm (If S ≥ 305 mm, S = ± 7,5 mm)

²⁾ Tolerance: S = ± 2,5 mm and L2 = ± 3,8 mm

Potentiometer resolution

Stroke (mm)	102	153	204	305	457	610
Ohm/mm	59,0	59,0	29,5	29,5	9,84	9,84

CAHB-20 series – made to last

Designed to operate in temperatures from –40 to 85 °C at a 25% duty cycle, SKF electromechanical actuator CAHB family features robust metal gears and corrosion-resistant housings*.

Validated for tough environments, SKF CAHB actuators are virtually maintenance-free, self-locking, IP 66-rated units. Additional design options are available.

Engineered to withstand a range of severe operating conditions, these actuators have undergone an extensive series of me-

chanical, environmental and electronic trials. The actuators proved to be resistant to wide temperature swings, chemicals, dirt, dust, water, shock, vibration and other demanding operating conditions, resulting in improved reliability.

* According 96h salt mist spray test (SIMD3–D05001 and ID8A–D05001)

Benefits

OEMs

- Take advantage of robust off-highway design and engineering
- Reduce time to market
- Cut engineering, testing and assembly costs
- Reduce warranty issues
- Adapt to application needs flexibly
- Enjoy local engineering and global service network support

End users

- Increase machine productivity
- Boost operator comfort and safety
- Reduce maintenance and ownership costs
- Reduced environmental impact

Actuator environmental validation testing

Passed

Operation under low temperatures (–40 °C)	✓
Operation under high temperatures (85 °C)	✓
Operation in dirty environments (IP 66)	✓
Operation without electromagnetic interference (EMC)	✓
Operation under vibration	✓

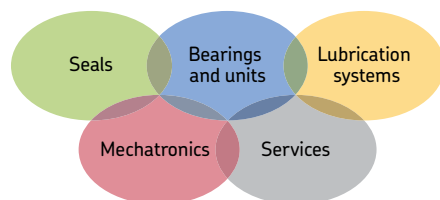

The Power of Knowledge Engineering

Drawing on five areas of competence and application-specific expertise amassed over more than 100 years, SKF brings innovative solutions to OEMs and production facilities in every major industry worldwide. These five competence areas include bearings and units, seals, lubrication systems, mechatronics (combining mechanics and electronics into intelligent systems), and a wide range of services, from 3-D computer modelling to advanced condition monitoring and reliability and asset management systems. A global presence provides SKF customers uniform quality standards and worldwide product availability.

© SKF is a registered trademark of the SKF Group

© SKF Group 2010

The contents of this publication are the copyright of the publisher and may not be reproduced (even extracts) unless prior written permission is granted. Every care has been taken to ensure the accuracy of the information contained in this publication but no liability can be accepted for any loss or damage whether direct, indirect or consequential arising out of the use of the information contained herein.

PUB MT/P2 10694 EN · April 2010



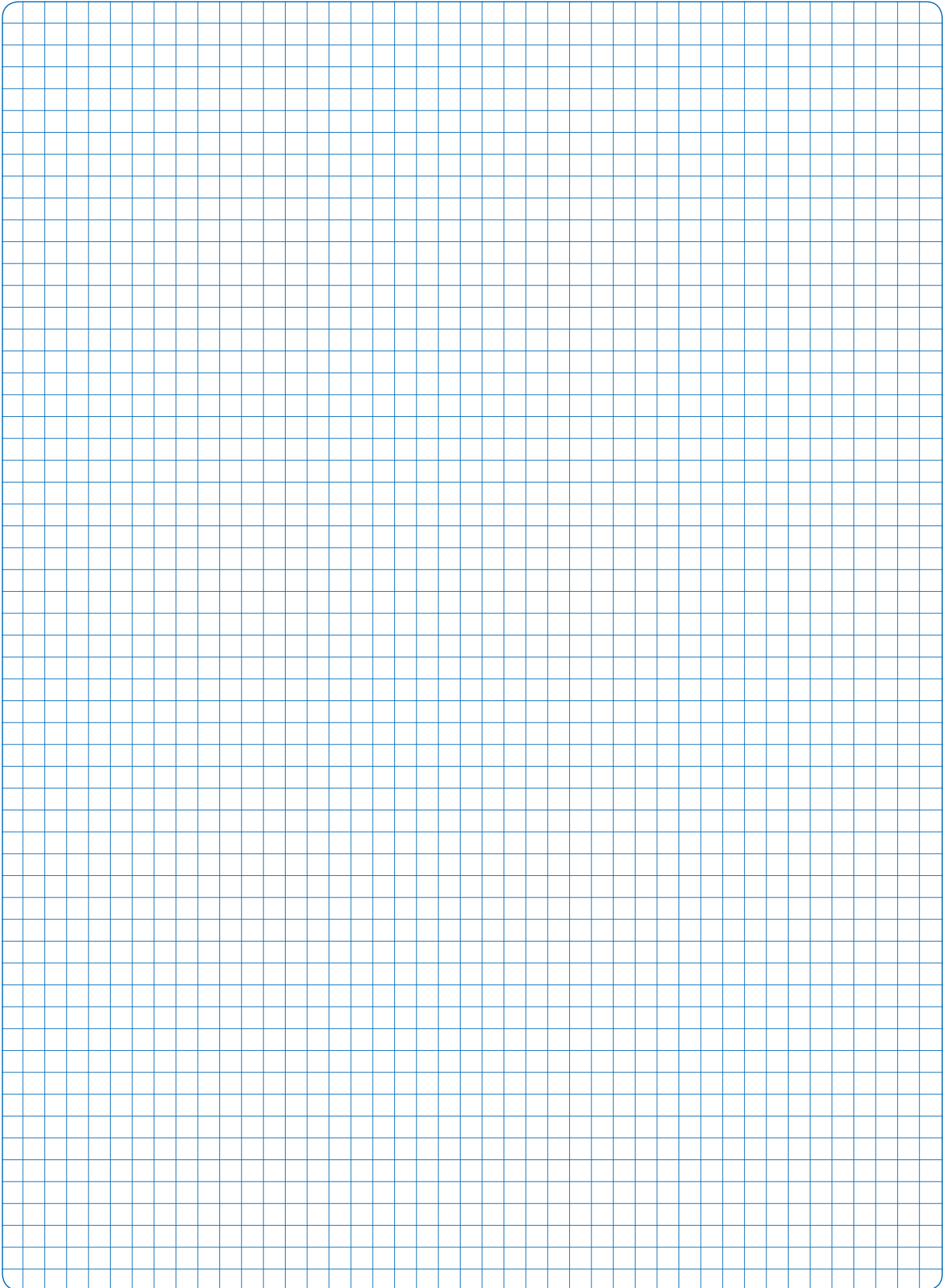

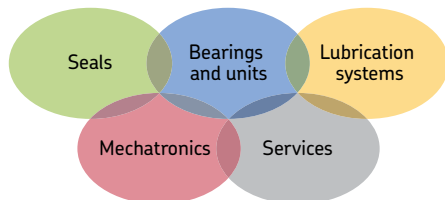

The Power of Knowledge Engineering

Drawing on five areas of competence and application-specific expertise amassed over more than 100 years, SKF brings innovative solutions to OEMs and production facilities in every major industry worldwide. These five competence areas include bearings and units, seals, lubrication systems, mechatronics (combining mechanics and electronics into intelligent systems), and a wide range of services, from 3-D computer modelling to advanced condition monitoring and reliability and asset management systems. A global presence provides SKF customers uniform quality standards and worldwide product availability.

Please contact:

SKF Taiwan Co., Ltd

(SKF Actuation System Taipei Branch)

No. 3, Lane 11, Tzu-Chiang St.,

Tu-Cheng Industrial District,

Taipei, Taiwan

Tel.: +886 2 2268 1133

Fax: +886 2 5592 1236

actuators@skf.com

© SKF is a registered trademark of the SKF Group.

© SKF Group 2010

The contents of this publication are the copyright of the publisher and may not be reproduced (even extracts) unless prior written permission is granted. Every care has been taken to ensure the accuracy of the information contained in this publication but no liability can be accepted for any loss or damage whether direct, indirect or consequential arising out of the use of the information contained herein.

PUB MT/14 10667 EN - August 2010

