

CASM-40

Siemens motors and adapters

In order to provide you a fully integrated system, SKF combined its actuator expertise with Siemens' well-known motor knowledge. Thanks to this partnership, SKF offers a complete linear solution, including a CASM linear unit mounted with a SIEMENS 1FK7 servomotor.

The Siemens motors 1FK7022 and 1FK7034 come with a multipole resolver, a shaft-end with no keyway and a holding brake. In addition, they are equipped with a DRIVE-CLiQ interface. A rotating plug adapter simplifies the connection and cable routing in all installation positions.

For more information, please visit the following sites:

Motors: www.siemens.com/motors

Frequency converters: www.siemens.com/sinamics

Automation systems: www.siemens.com/simotion

Controls: www.siemens.com/simatic

Engineering software: www.siemens.com/sizer

Support worldwide: www.siemens.de/service

Solutions with Siemens motor 1FK7022 and compatible adapters

Order N°
1FK7022-5AK71-1UH3

Dimensional drawing Siemens motor 1FK7022

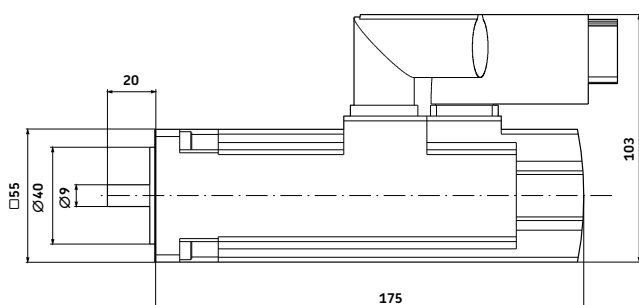

Motor data

	Unit	1FK7022
Rated power (100 K)	kW	0,43
Rated speed	min ⁻¹	6 000
Rated current	A	1,4
Rated torque (100 K)	Nm	0,6
Static torque (100 K)	Nm	0,85
Peak torque	Nm	3,4
Inertia with brake	10 ⁻⁴ kgm ²	0,35
Shaft height	mm	28
Weight with brake	kg	2

Parallel adapter kit for CASM-40 and Siemens 1FK7022 motor*

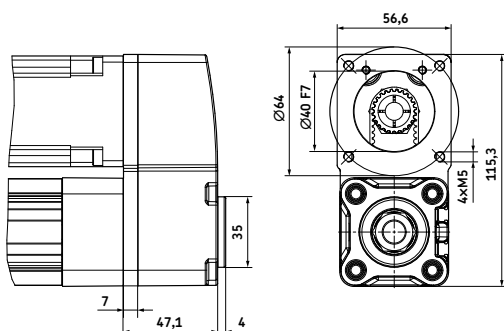

* Screws included

Order N°
ZBE-375541



System capabilities

	Unit	Peak force	Fm ¹⁾
CASM-40-LS	N	600	408
CASM-40-BS	N	2 375	640
CASM-40-BN	N	1 550	301

¹⁾ RMS force over full cycle. For more information, please visit www.skf.com/casm



In-line adapter kit for CASM-40 and Siemens 1FK7022 motor*

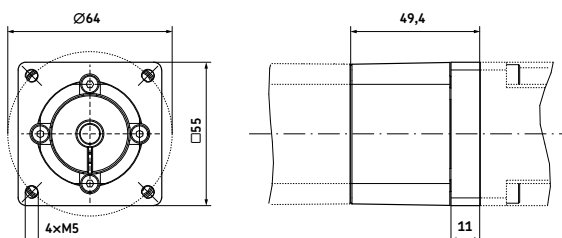

* Screws included



Order N°
 ZBE-375532

System capabilities

	Unit	Peak force	Fm ¹⁾
CASM-40-LS	N	600	408
CASM-40-BS	N	2 375	640
CASM-40-BN	N	1 318	301

¹⁾ RMS force over full cycle. For more information, please visit www.skf.com/casm

Solution with Siemens motor 1FK7034 and compatible adapter

Dimensional drawing Siemens motor 1FK7034

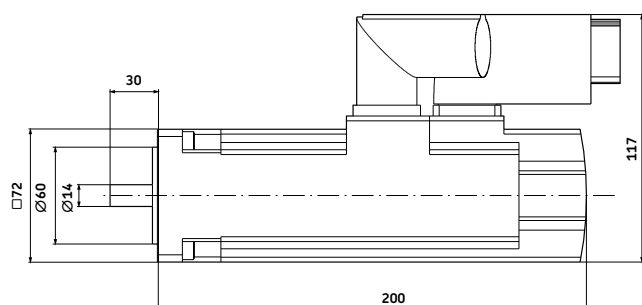

Order N°
 1FK7034-5AK71-1UH3

Motor data

	Unit	1FK7034
Rated power (100 K)	kW	0,63
Rated speed	min ⁻¹	6 000
Rated current	A	1,3
Rated torque (100 K)	Nm	1
Static torque (100 K)	Nm	1,6
Peak torque	Nm	6,5
Inertia with brake	10 ⁻⁴ kgm ²	0,98
Shaft height	mm	36
Weight with brake	kg	4

In-line adapter kit for CASM-40 and Siemens 1FK7034 motor*

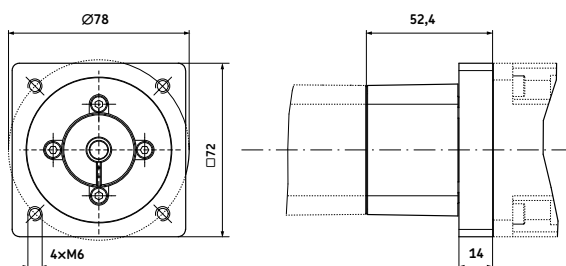

* Screws included



Order N°
 ZBE-375533

System capabilities

	Unit	Peak force	Fm ¹⁾
CASM-40-LS	N	600	600
CASM-40-BS	N	2 375	1 219
CASM-40-BN	N	1 550	572

¹⁾ RMS force over full cycle. For more information, please visit www.skf.com/casm